

3-EVF-150(6V150AH/3HR)

LONG WAY 3-EVF-150 is one of the Deep Cycle series of Kaiying Power Supply & Electrical Equip Co.,Ltd.The series adopt new materiel,new technology,new process,with higher weight ratio of energy and good resistance to vibration performance ,a good consistency,high charge rate,deep discharge recovery,low self discharge,sealed and maintenance free.It is quiet suitable for using as electrical system of electric road vehicles, applications widely in low speed electric vehicles,golf car travel car,old scooter,electrical wheel chair,electric sanitation vehicles and police patrol car etc.



Specification:

Nominal Voltage (V)		6V
The Open Circuit Voltage (V)		6.45—6.66V
Cells per Unit		3
Discharge Capacity at 25 °C (AH)	1Hr-rate(105Ato1.60Vper cell)	109.5AH
	2Hr-rate(66Ato1.60Vper cell)	142.5AH
	3Hr-rate(50Ato1.70Vper cell)	150.0AH
	5Hr-rate(32Ato1.75Vper cell)	187.5AH
Average weight/kg		30.0kg
Container material		ABS(UL94-HB)
Charge voltage/V	Float charge (V)	6.90---7.05V
	Cycle (V)	7.20---7.50V
Maximum discharge current/A		750A
Reasonable charge current/A		30.0A
Terminal type		F12
Screw stem		M8 stem
25°C Self discharge rate		Less than3% per month
Operate temperature range		Discharge: -15~50°C Charge: -15°C~40°C Storage: -15°C~40°C

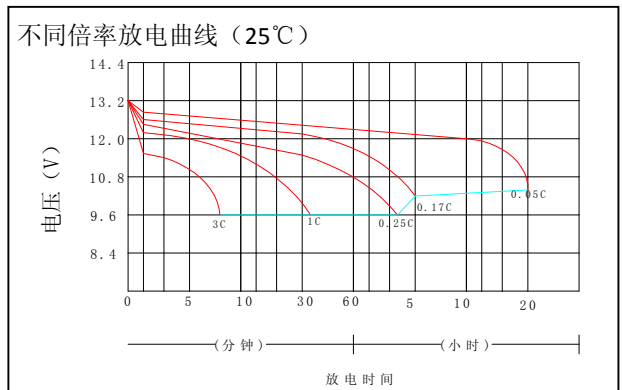
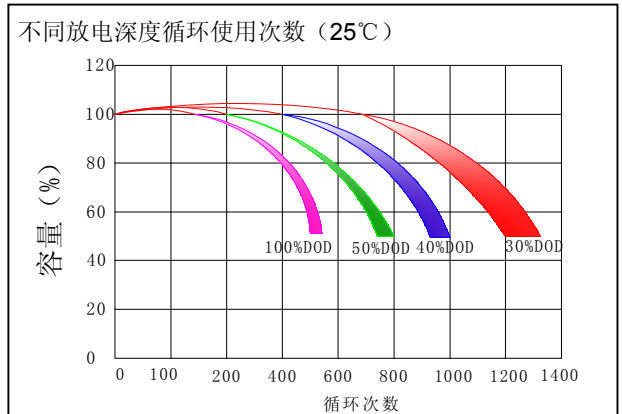

Dimensions: length260±2mm; width180±2mm; height 246±2mm; total height 250±2mm

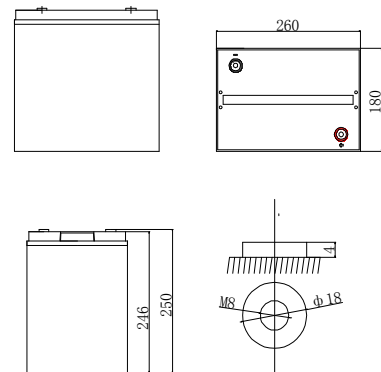

Address: KaiYing Industrial, ChengXiang Town, AnXi, QuanZhou, Fujian, China

Tel: 0595-68782266 Fax: 0595-68782222

Web: www.longwaybattery.com Email: sales@longwaybattery.com

Version number: A0 April, 2015

Statement: The information is just a profile of product,not a guarantee of any battery.The parameters of battery could be modified independently without