



# 样品规格书

产品名称：0.56 "两位红色数码管 Product Name: LED Display	发光颜色:红色 Emitted Color:	封胶: 封胶 Filler: Resin
产品型号: Product No: JMD-5261CS-016	极性: 共阴 Polarity:	面色: 黑面白胶
产品编码: Product Code:	样品单号: Sample NO:	
注: 所有材料均符合 ROHS 要求 All materials are RoHS compliant!		

## SPECIFICATION

日期: Date:	承办人: Issuer:
--------------	-----------------

## 客户确认 APPROVED BY

客户: Customer:	签名: Signature:
机型: Model No:	日期: Date:
料号: Part No:	

结论 Result :

确认后请回传 PLEASE RETURN BY A COPY

设计 (DESIGN): \_\_\_\_\_ 检查 (CHECKED): \_\_\_\_\_ 批准 (APPROVED): \_\_\_\_\_



## 产品说明书

### 1. 极限参数 (Absolute Maximum Ratings)

#### (1) 红色(Red)

参数 (Parameter)	符号 (Symbol)	极限值 (Maximum Rating)	单位 (Unit)
功耗 (Power Dissipation)	Pd	80	mW
脉冲电流 (Peak Forward Current)	I <sub>fp</sub>	90	mA
直流电流 (Continuous Forward Current)	I <sub>fm</sub>	20	mA
反向电压 (Reverse Voltage)	V <sub>R</sub>	5	V
工作温度 (Operating Temperature Range)	T <sub>opr</sub>	-20 → +85	°C
储藏温度 (Storage Temperature Range)	T <sub>stg</sub>	-20 → +85	°C
静电电压 (Static Voltage)	V <sub>ar</sub>		V

\*焊接温度 (Lead Soldering Temperature): 260°C for 3 seconds

\*当工作温度高于 25°C 时, I<sub>fm</sub>、I<sub>fp</sub>、Pd 必须降低; 电流降低率是-0.36mA/°C (直流驱动), 或-0.86mA/°C (脉冲驱动) 功耗降低率是-0.75mW/°C。

The I<sub>fm</sub> I<sub>fp</sub> & Pd must be decreased once the temperature is over 25 °C; the Current decrease rate is: -0.36mA/°C (Direct Current); -0.86mA/°C (Pulse drive) the power dissipation is -0.75mW/°C

### 2. 光电特性 (Optical-Electrical Characteristic)

#### (1) 红色(Red)

参数 (Parameter)	测试条件 (Test)	符号 (Symbol)	Min	Type	Max	单位 (Unit)
发光强度 (Luminous Intensity)	I <sub>F</sub> =20mA	I <sub>v</sub>	30		35	Mcd
正向电压 (Forward Voltage)	I <sub>F</sub> =20mA	V <sub>F</sub>	1.7		2.5	V
反向电流 (REVERSE Current)	V <sub>R</sub> = 5V	I <sub>R</sub>	-	-	50	uA
主波长 (Wavelength)	I <sub>F</sub> =20mA	λ <sub>D</sub>	630		635	nm
查看角度 (View Angle)	I <sub>F</sub> =20mA	2θ <sub>1/2</sub>	-	60	-	Deg.

### 3. 结构尺寸、原理图 (Mechanical Dimension and Circuit Diagram) :

(未注尺寸公差 Unspecified Tolerances is:  $X \pm 0.2$  )

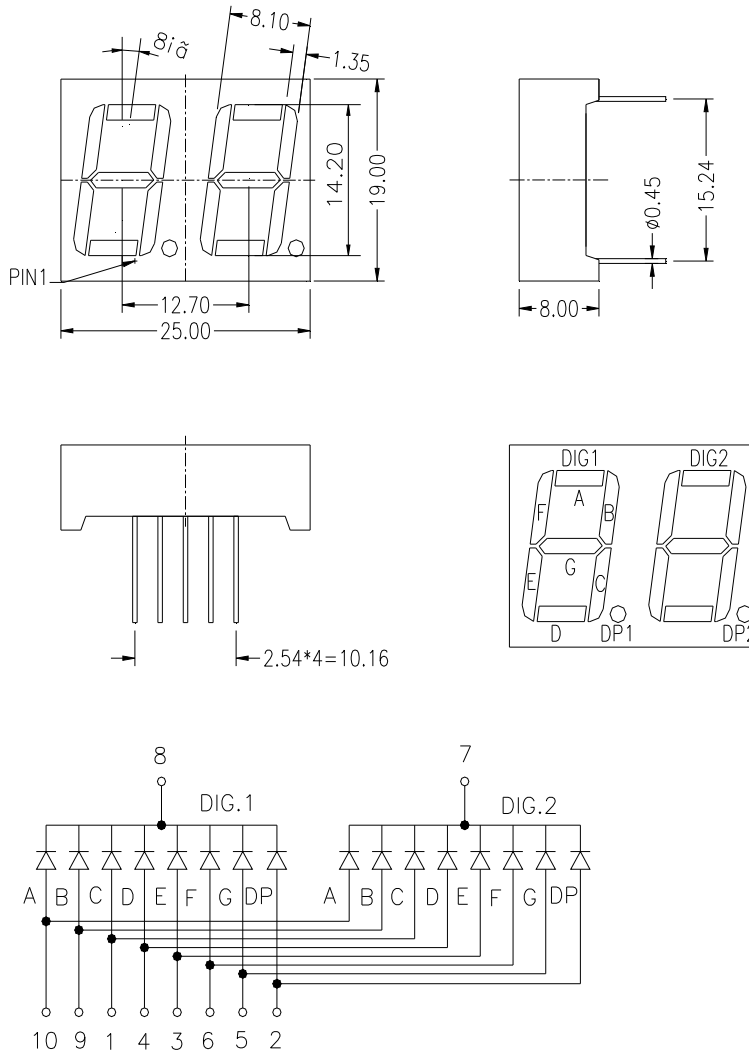

### 4. 保存和焊接条件 (Storage & Soldering Conditions) :

- ℓ Store with care. Storing the units in bad condition will decrease the adhesive power between the reflector and film. 注意保存, 保存条件不好时, 会降低膜片与反射壳 (导光板) 的粘附力。 Recommend storage condition : temperature (  $25^{\circ}\text{C} \pm 10^{\circ}\text{C}$  ) 推荐保存条件为: 温度  $25^{\circ}\text{C} \pm 10^{\circ}\text{C}$  and humidity (  $65^{\circ}\text{C CRH} \pm 20^{\circ}\text{C CRH}$  ) 湿度  $65^{\circ}\text{C CRH} \pm 20^{\circ}\text{C CRH}$
- ℓ The Soldering Temperature is  $260 \pm 5^{\circ}\text{C}$  and Soldering time should be less than 3 seconds, and soldering iron power should be less than 30W. 焊接温度  $260^{\circ}\text{C} \pm 5^{\circ}\text{C}$ , 焊接时间小于 3 秒, 烙铁功率小于 30W。
- ℓ The soldering point should be at least 1.6mm away from the body. 焊接点应离产品实体大于 1.6mm。



5. 光电特性曲线 (Typical Electro optical Characteristics Curve):

