



样品规格书

产品名称：0.5 "两位白光数码管 Product Name: LED Display	发光颜色：白色 Emitted Color:	封胶：封胶 Filler: Resin
产品型号： Product No: JMD-5202FW-016	极性：共阳 Polarity:	面色：黑面黄胶
产品编码： Product Code:	样品单号： Sample NO:	
注：所有材料均符合 ROHS 要求 All materials are RoHS compliant!		

SPECIFICATION

日期： Date:	承办人： Issuer:
--------------	-----------------

客户确认 APPROVED BY

客户： Customer:	签名： Signature:
机型： Model No:	日期： Date:
料号： Part No:	

结论 Result :

确认后请回传 PLEASE RETURN BY A COPY

设计 (DESIGN): _____ 检查 (CHECKED): _____ 批准 (APPROVED): _____



产品说明书

1. 极限参数 (Absolute Maximum Ratings)

(1) 白色(White)

参数 (Parameter)	符号 (Symbol)	极限值 (Maximum Rating)	单位 (Unit)
功耗 (Power Dissipation)	Pd	80	mW
脉冲电流 (Peak Forward Current)	I _{fp}	90	mA
直流电流 (Continuous Forward Current)	I _{fm}	20	mA
反向电压 (Reverse Voltage)	V _R	5	V
工作温度 (Operating Temperature Range)	T _{opr}	-20 → +85	°C
储藏温度 (Storage Temperature Range)	T _{stg}	-20 → +85	°C
静电电压 (Static Voltage)	V _{ar}		V

*焊接温度 (Lead Soldering Temperature): 260°C for 3 seconds

*当工作温度高于 25°C 时, I_{fm}、I_{fp}、Pd 必须降低; 电流降低率是-0.36mA/°C (直流驱动), 或-0.86mA/°C (脉冲驱动) 功耗降低率是-0.75mW/°C。

The I_{fm} I_{fp} & Pd must be decreased once the temperature is over 25 °C; the Current decrease rate is: -0.36mA/°C (Direct Current); -0.86mA/°C (Pulse drive) the power dissipation is -0.75mW/°C

2. 光电特性 (Optical-Electrical Characteristic)

(1) 白色(White)

参数 (Parameter)	测试条件 (Test)	符号 (Symbol)	Min	Type	Max	单位 (Unit)
发光强度 (Luminous Intensity)	I _F =20mA	I _v	600	650	720	Mcd
正向电压 (Forward Voltage)	I _F =20mA	V _F	2.7	3.0	3.8	V
反向电流 (REVERSE Current)	V _R = 5V	I _R	-	-	50	uA
波长 (Peak Wavelength)	I _F =20mA	X	/	0.2639	0.2857	
		Y	/	0.2881	0.3183	
带宽 (Spectral Bandwidth)	I _F =20mA	Δλ	-	30	-	nm
查看角度 (View Angle)	I _F =20mA	2θ _{1/2}	-	60	-	Deg.

3. 结构尺寸、原理图 (Mechanical Dimension and Circuit Diagram) :

(未注尺寸公差 Unspecified Tolerances is: $X \pm 0.2$)

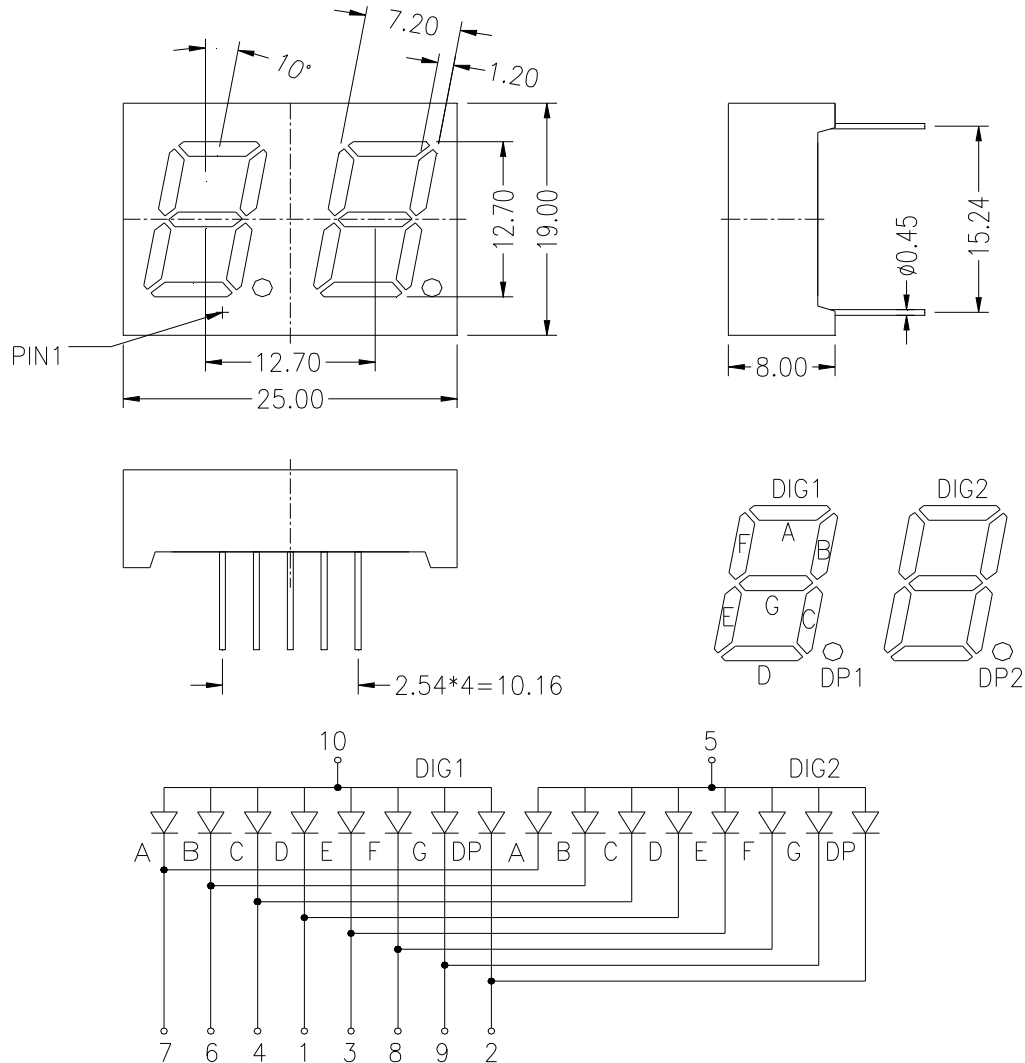

4. 保存和焊接条件 (Storage & Soldering Conditions) :

- ℓ Store with care. Storing the units in bad condition • 注意保存, 保存条件不好时, 会降低膜片 will decrease the adhesive power between the reflector and film. 与反射壳 (导光板) 的粘附力。 Recommend storage condition : temperature ($25^{\circ}\text{C} \pm 10^{\circ}\text{C}$) 推荐保存条件为: 温度 $25^{\circ}\text{C} \pm 10^{\circ}\text{C}$ and humidity ($65\% \text{ CRH} \pm 20\% \text{ CRH}$) 湿度 $65\% \text{ CRH} \pm 20\% \text{ CRH}$
- ℓ The Soldering Temperature is $260 \pm 5^{\circ}\text{C}$ and Soldering time should be less than 3 seconds, and soldering iron power should be less than 30W. • 焊接温度 $260^{\circ}\text{C} \pm 5^{\circ}\text{C}$, 焊接时间小于 3 秒, 烙铁功率小于 30W。
- ℓ The soldering point should be at least 1.6mm away from the body. • 焊接点应离产品实体大于 1.6mm。



5. 光电特性曲线 (Typical Electro optical Characteristics Curve):

