

**N Channel MOSFET**

 Lead Free Package and Finish

**Applications:**

- Adapter & Charger
- SMPS Standby Power
- AC-DC Switching Power Supply
- LED driving power

$I_D$	$R_{DS(ON)}$ (Typ. )	$V_{DSS}$
10A	0.92 $\Omega$	800V

**Features:**

- Low On Resistance
- Low Gate Charge
- Peak Current vs Pulse Width Curve
- RoHS Compliant

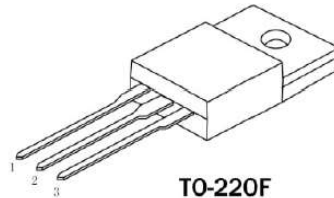

**TO-220F**

Not to Scale

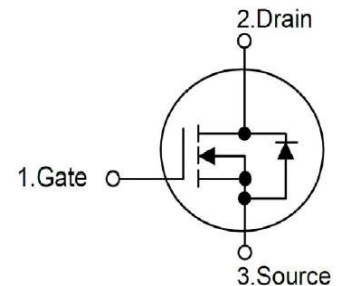

**Ordering Information**

Part Number	Package	Marking
RS10N80F	TO-220F	RS10N80F

**Absolute Maximum Ratings  $T_c=25^\circ\text{C}$  unless otherwise specified**

Symbol	Parameter	RS10N80F	Units
$V_{DSS}$	Drain-to-Source Voltage (Note*1)	800	V
$I_D$	Continuous Drain Current	10.0	A
$I_{D@ 100^\circ\text{C}}$	Continuous Drain Current	6.3	
$I_{DM}$	Pulsed Drain Current (Note*2)	40.0	
$P_D$	Power Dissipation	62	W
	Derating Factor above $25^\circ\text{C}$	0.5	$\text{W}/^\circ\text{C}$
$V_{GS}$	Gate-to-Source Voltage	$\pm 30$	V
$E_{AS}$	Single Pulse Avalanche Energy $L=30\text{mH}$ $I_{AS}=7.5\text{A}$ $V_{DD}=100\text{V}$ $R_G=25\Omega$ $T_J=25^\circ\text{C}$	938	mJ
$T_L$ $T_{PKG}$	Maximum Temperature for Soldering	300 260	$^\circ\text{C}$
	Leads at 0.063in(1.6mm)from Case for 10 seconds		
	Package Body for 10 seconds		
$T_J$ and $T_{STG}$	Operating Junction and Storage Temperature Range	-55 to 150	

\*Drain Current Limited by Maximum Junction Temperature

Caution:Stresses greater than those listed in the “Absolute Maximum Ratings” Table may cause permanent damage to the device.

**Thermal Resistance**

Symbol	Parameter	RS10N80F	Units	Test Conditions
$R_{\theta JC}$	Junction-to-Case	2.02	$^\circ\text{C}/\text{W}$	Drain lead soldered to water cooled heatsink, $P_D$ adjusted for a peak junction temperature of $+150^\circ\text{C}$ .
$R_{\theta JA}$	Junction-to-Ambient	62.5		1 cubic foot chamber, free air.

**OFF Characteristics**  $T_J=25^{\circ}\text{C}$  unless otherwise specified

Symbol	Parameter	Min.	Typ.	Max.	Units	Test Conditions
BV <sub>DSS</sub>	Drain-to-source Breakdown Voltage	800	--	--	V	V <sub>GS</sub> =0V, I <sub>D</sub> =250 $\mu$ A
I <sub>DSS</sub>	Drain-to-Source Leakage Current	--	--	1.0	$\mu$ A	V <sub>DS</sub> =800V, V <sub>GS</sub> =0V
I <sub>GSS</sub>	Gate-to-Source Forward Leakage	--	--	100	nA	V <sub>GS</sub> =+30V V <sub>DS</sub> =0V
	Gate-to-Source Reverse Leakage	--	--	-100		V <sub>GS</sub> =-30V V <sub>DS</sub> =0V

**ON Characteristics**  $T_J=25^{\circ}\text{C}$  unless otherwise specified

Symbol	Parameter	Min.	Typ.	Max.	Units	Test Conditions
R <sub>DS(on)</sub>	Static Drain-to-Source On-Resistance	--	0.92	1.15	$\Omega$	V <sub>GS</sub> =10V, I <sub>D</sub> =5.0A
V <sub>GS(TH)</sub>	Gate Threshold Voltage	2.0	--	4.0	V	V <sub>GS</sub> =V <sub>DS</sub> , I <sub>D</sub> =250 $\mu$ A

**Resistive Switching Characteristics** Essentially independent of operating temperature

Symbol	Parameter	Min.	Typ.	Max.	Units	Test Conditions
t <sub>d(ON)</sub>	Turn-on Delay Time	--	26.88	--	nS	V <sub>DS</sub> =400V I <sub>D</sub> =10A R <sub>G</sub> =25 $\Omega$ (Note:3, 4)
t <sub>rise</sub>	Rise Time	--	40.44	--		
t <sub>d(OFF)</sub>	Turn-OFF Delay Time	--	89.20	--		
t <sub>fall</sub>	Fall Time	--	42.88	--		

**Dynamic Characteristics** Essentially independent of operating temperature

Symbol	Parameter	Min.	Typ.	Max.	Units	Test Conditions
C <sub>iss</sub>	Input Capacitance	--	1626	--	pF	V <sub>GS</sub> =0V V <sub>DS</sub> =25V f=1.0MHz
C <sub>oss</sub>	Output Capacitance	--	150.8	--		
C <sub>rss</sub>	Reverse Transfer Capacitance	--	6.5	--		
Q <sub>g</sub>	Total Gate Charge	--	33.34	--	nC	V <sub>DS</sub> =640V I <sub>D</sub> =10A V <sub>GS</sub> =10V (Note:3, 4)
Q <sub>gs</sub>	Gate-to-Source Charge	--	8.57	--		
Q <sub>gd</sub>	Gate-to-Drain("Miller") Charge	--	12.63	--		

Source-Drain Diode Characteristics

Symbol	Parameter	Min.	Typ.	Max.	Units	Test Conditions
I <sub>S</sub>	Continuous Source Current	--	--	10.0	A	Integral pn-diode in MOSFET
I <sub>SM</sub>	Maximum Pulsed Current	--	--	40.0	A	
V <sub>SD</sub>	Diode Forward Voltage	--	--	1.4	V	I <sub>S</sub> =10A, V <sub>GS</sub> =0V
t <sub>rr</sub>	Reverse Recovery Time	--	610.80	--	nS	V <sub>GS</sub> =0V I <sub>S</sub> =10A, di/dt=100A/μs
Q <sub>rr</sub>	Reverse Recovery Charge	--	5.6	--	μC	

Notes:

- \*1. T<sub>J</sub>=±25°C to +150°C.
- \*2. Repetitive rating; pulse width limited by maximum junction temperature.
- \*3. Pulse width ≤ 300μs; duty cycle ≤ 2%.
- \*4. Basically not affected by temperature.

Typical Feature curve

Figure1. Typical Output Characteristics

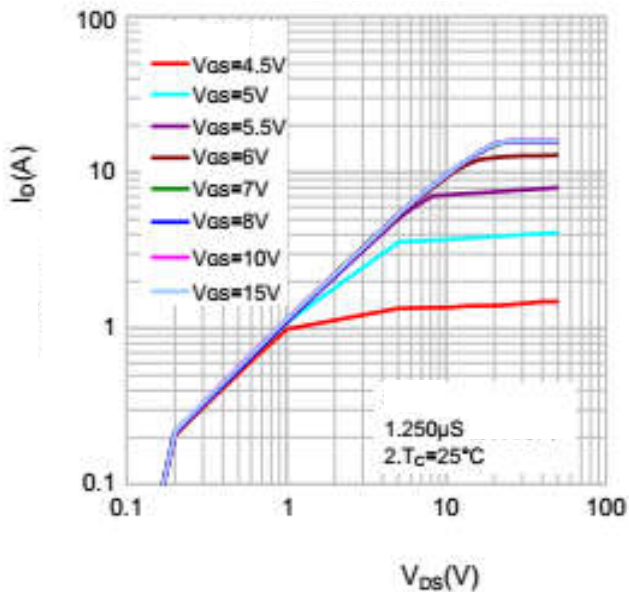
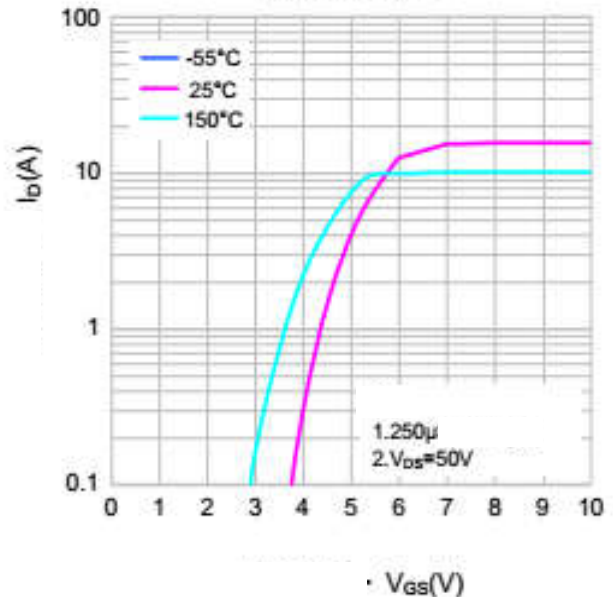
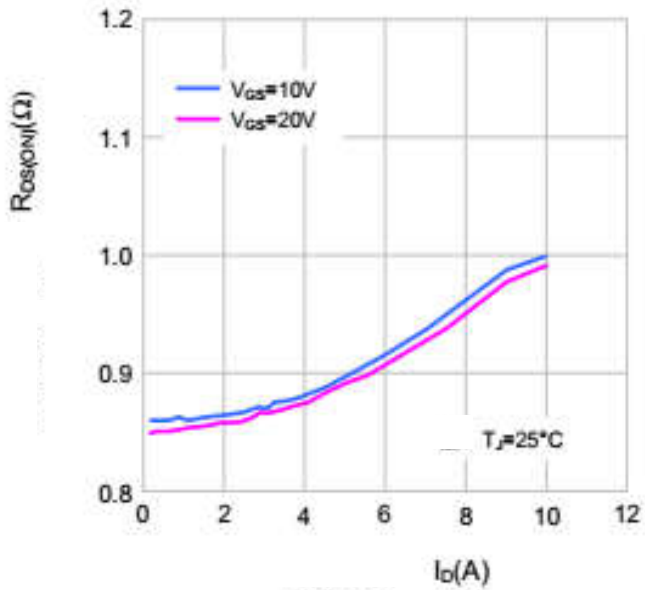

Figure2. Typical Transfer Characteristics



Figuer3. Typical ON Resistance vs Drain Current



Figuer4. Typical Body Diode Transfer Characteristics

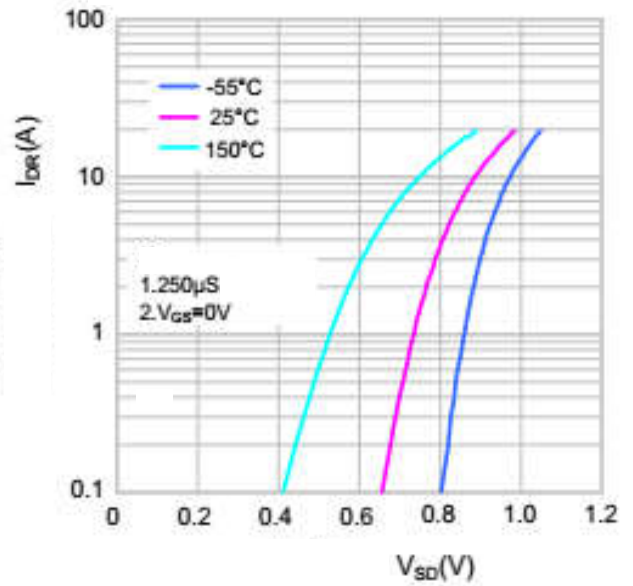

Figure5. Typical Capacitance vs Drain-to-Source Voltage

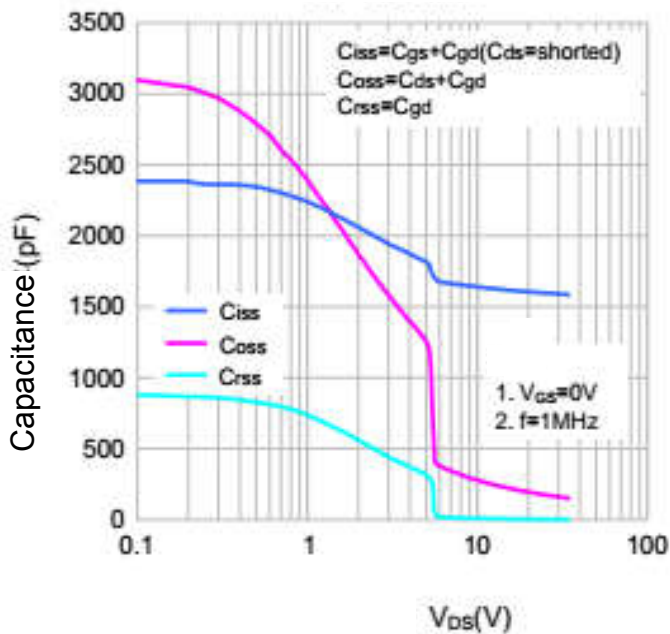

Figure6. Typical Gate Charge vs Gate-to-Source Voltage

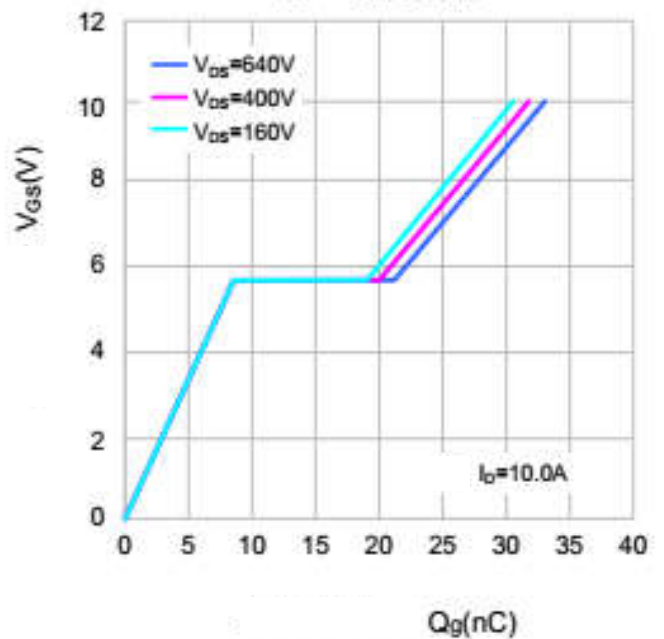

Figure7. Typical Breakdown Voltage vs Junation Temperature

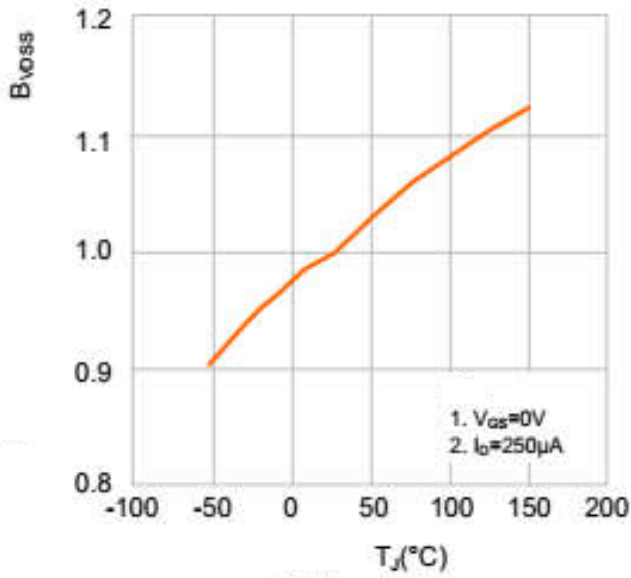

Figure8. Figure10. Typical Drain-to-Source ON Resistance vs Junction Temperature

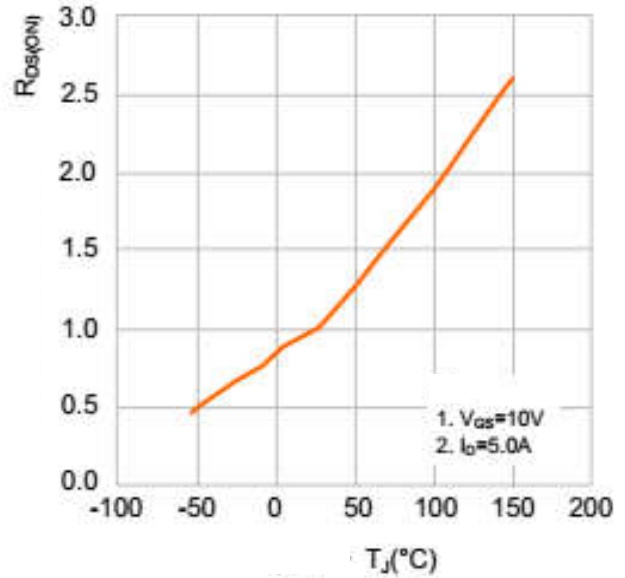

Figure9. Maximum Continuous Drain Current vs Case Temperature

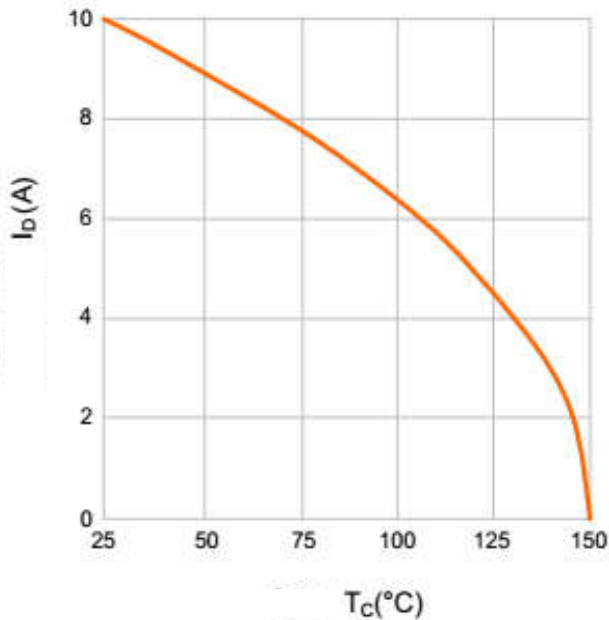
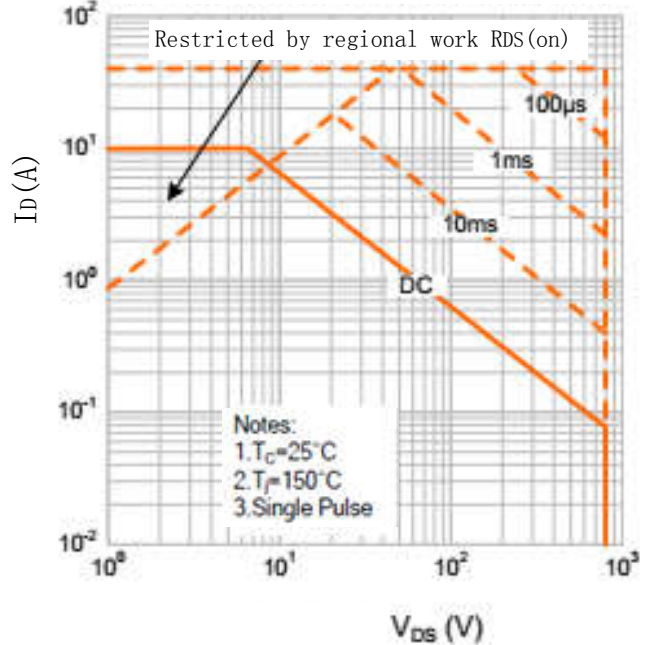

Figure10. Maximum Continuous Drain Current vs Case Temperature



Test Circuits and Waveforms

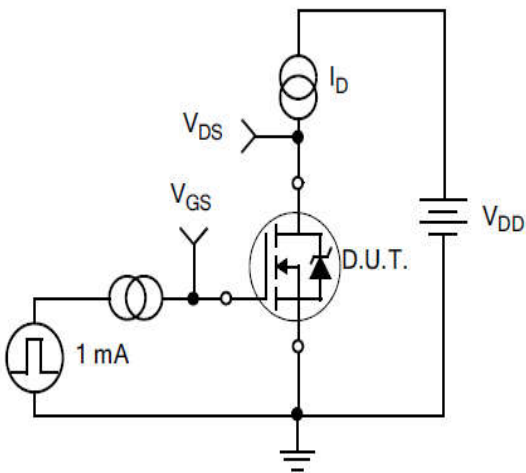

Figure11.  
Gate Charge Test Circuit

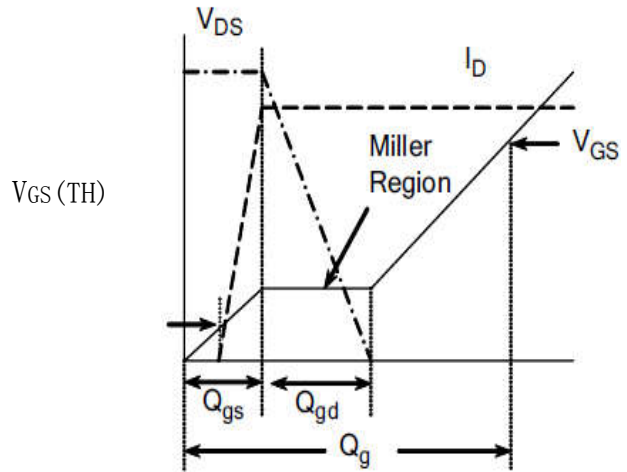

Figure12.  
Gate Charge Waveform

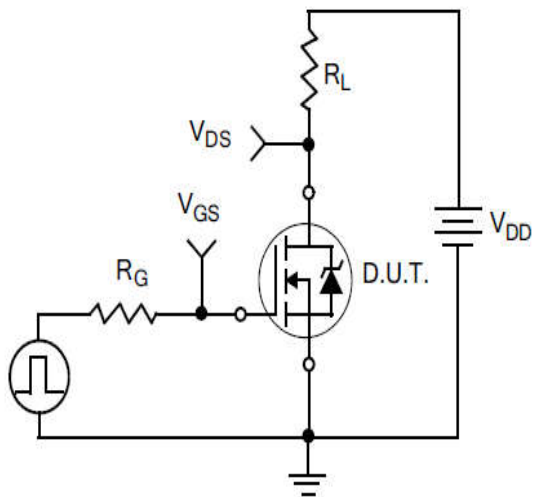

Figure13.  
Resistive Switching Test Circuit

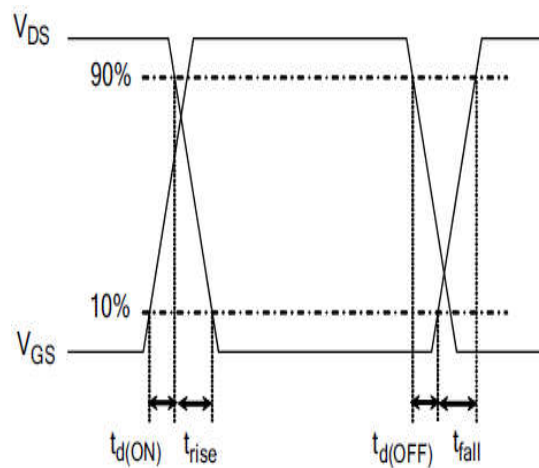

Figure14.  
Resistive Switching Waveforms

Test Circuits and Waveforms

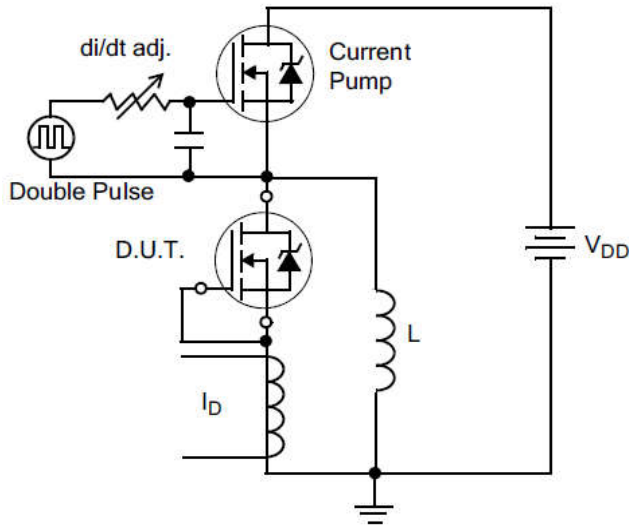

Figure15. Diode Reverse Recovery Test Circuit

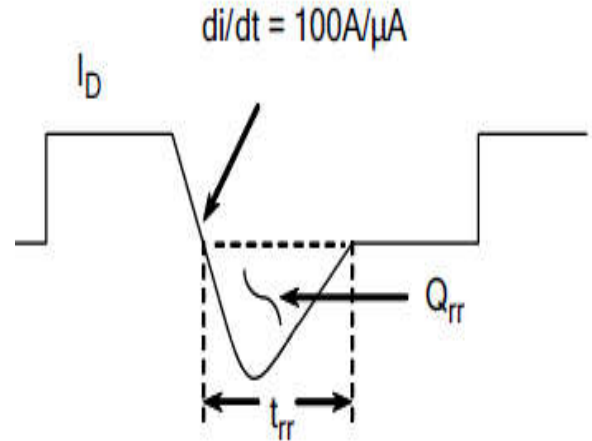

Figure16. Diode Reverse Recovery Waveform

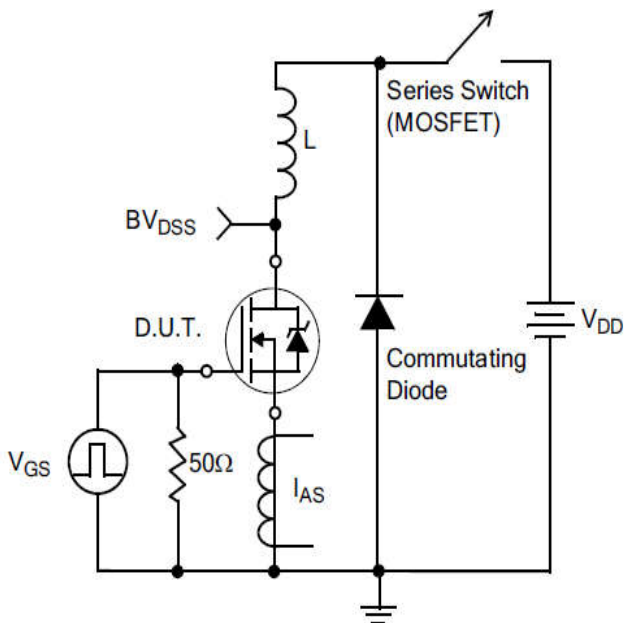
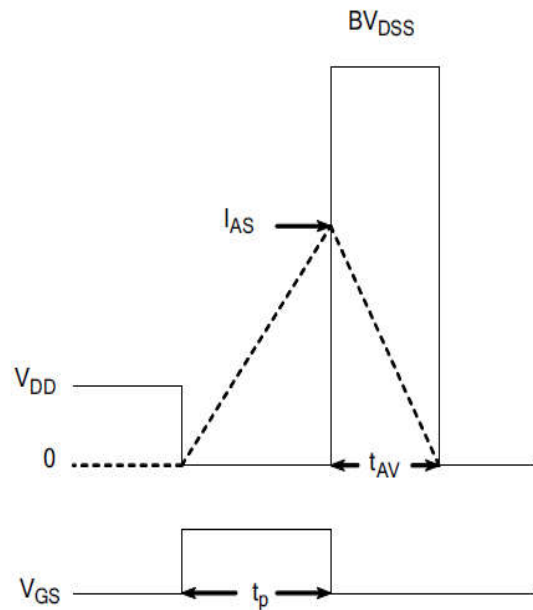

Figure17. Unclamped Inductive Switching Test Circuit



$$EAS = \frac{I_{AS}^2 L}{2}$$

Figure18. Unclamped Inductive Switching Waveforms

Package outline drawing

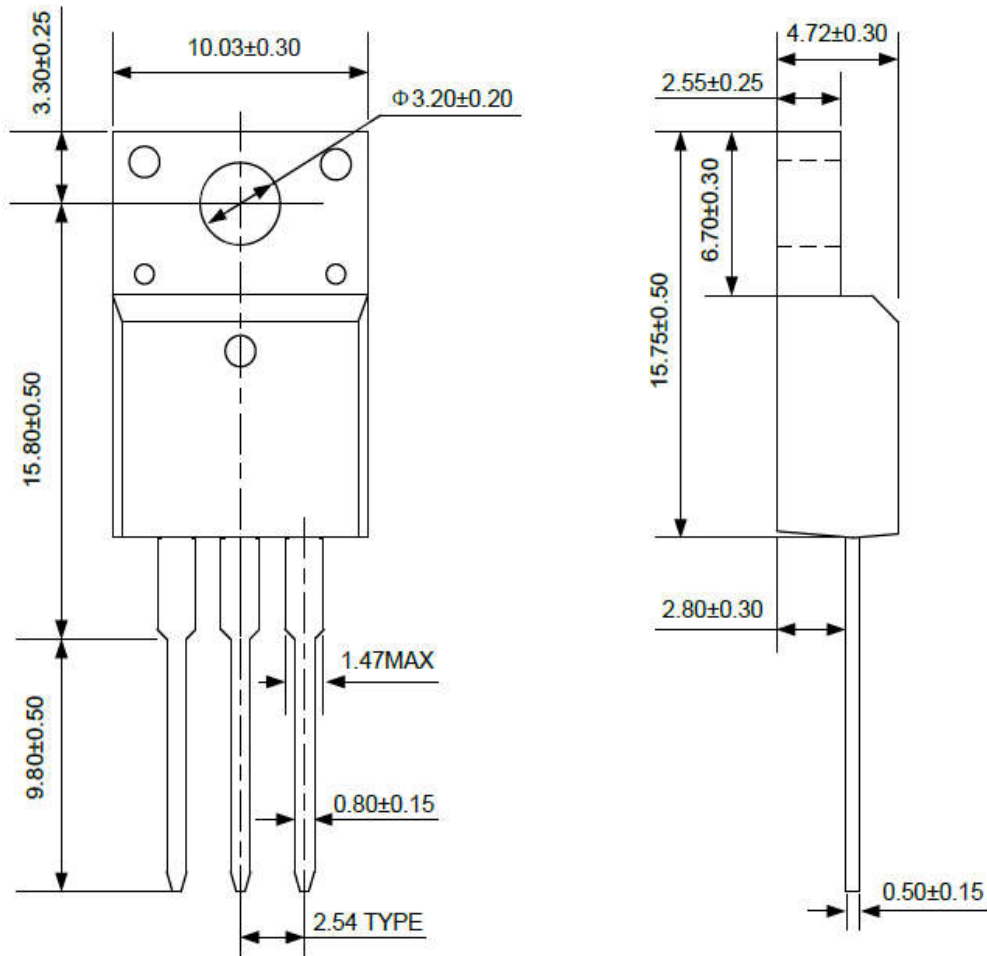

TO-220F



**Disclaimers:**

GuangDong Reasunos Semiconductor Technology CO.,LTD(Reasunos)reserves the right to make changes without notice in order to improve reliability,function or design and to discontinue any product or service without notice .Customers should obtain the latest relevant information before orders and should verify that such information in current and complete.All products are sold subject to Reasunos's terms and conditions supplied at the time of order acknowledgement.

GuangDong Reasunos Semiconductor Technology CO.,LTD warrants performance of its hardware products to the specifications at the time of sale.Testing,reliability and quality control are used to the extene Reasunos deems necessary to support this warrantee. Except where agreed upon by contr-actual agreement,testing of all parameters of each product is not necessarily performed.

GuangDong Reasunos Semiconductor Technology CO.,LTD does not assume any liability arising from the use of any product or circuit designs described herein.Customers are responsible for their products and applications using Reasunos's components.To minimize risk,customers must provide adequate design and operating safeguards.

GuangDong Reasunos Semiconductor Technology CO.,LTD does not warrant or convey any license either expressed or implied under its patent rights,nor the rights of others.Reproduction of information in Reasunos's data sheeets or data books is permissible only if reproduction is without modification oralteration.Reproduction of this information with any alteration is an unfair and deceptive business practice.GuangDong Reasunos Semiconductor Technology CO.,LTD is not responsible or liable for such altered documentation.

Resale of Reasunos's products with statements different from or beyond the parameters stated by GuangDong Reasunos Semiconductor Technology CO.,LTD for that product or service voids all express or implied warranties for the associated Reasunos's product or service and is unfair and deceptive business practice.GuangDong Reasunos Semiconductor Technology CO.,LTD is not responsible or liable for such statements.

---

**Life Support Policy:**

GuangDong Reasunos Semiconductor Technology CO.,LTD's Products are not authorized for use as critical components in life support devices or systems without the expressed written approval of GuangDong Reasunos Semiconductor Technology CO.,LTD.

As used herein:

- 1.Life support devices or systems are devices or systems which:
    - a.are intended for surgical implant into the human body,
    - b.support or sustain life,
    - c.whose failuer to when properly used in accordance with instructions for used provided in the laeling,can be reasonably expected to result in significant injury to the user.
  - 2.A critical component is any component of a life support device or system whose failure to system whose failure to perform can be reasonably expected to cause the failure of the life support device or system,or to affect its safety or effectiveness.
-