

COLOR ASSESSMENT CABINET

BEVS 1201

User Manual



Version 201412

This manual shall be read carefully before starting. Directions included in this operation manual shall be strictly followed.

Content

- 1 Company Profile**
- 2 Product Introduction**
 - 2.1 Introduction
 - 2.2 Technical Specification
 - 2.3 Features
- 3 Operation Introduction**
 - 3.1 Cabinet Installation
 - 3.2 Construction
 - 3.3 Operation Guideline
 - 3.4 System Settings
- 4 Maintenance**
- 5 Attention**
- 6 Packing List**
- 7 Order Information of Accessories**

1 Company Profile

BEVS Industrial Co.,Ltd. is a leading manufacturer that specializes in coatings, ink, painting, resin testing instruments and laboratory whole solution.

We offer the complete and unique products in this field to meet customer's challenging demands of today and tomorrow, the products are complied with the standards of ISO, ASTM, DIN, BS, EN etc.

With strong supports and hard work by lots of end-users and worldwide agents, BEVS become more and more famous in the world and provides more competitive values for our customers.

2 Product Introduction

Color Assessment Cabinet is widely used in textile, printing and dyeing, printing, plastics, pigments, paints, inks, color photography and other fields, for accurate proofreading the color deviation of goods. Because of different light sources have different radiation energy when irradiated to the article, will show a different color. Although quality inspector has already compared the color with the sample carefully during the industrial production color management, because the light source is not inconsistent with environmental standards light source or the light source which customers used, the color is hard to verdict.

To effectively solve above problems, the most useful method is the verification of goods color, must be in the same light source and controlled conditions. For example the artificial light D65 is often used as the standard light source to evaluate commodity color in the international standard. Especially in the night time, using standard light source to calibrate is especially important for color deviation. Color Assessment Cabinet, in addition to providing the D65 light source, also provides TL84, CWF, UV, F, A light source, all have the function to test metamerism effect .

2.1 Introduction

To reduce the assessment error when performing color contrast, it is easy to simulate different light sources to compare color difference via touch screen panel. Ideal application for the Graphic arts, Photographic, Textile, Dyeing, Packaging, Printing, Leather, Inks, Knitwear, Plastic, Automotive and Ceramics industries.

2.2 Technical Specification

2.2.1 Illuminants:

Light Source	Color viewing booths Application	Color temperature(K)	Power(W)
D65	International standard Artificial Daylight	6500	18
TL84	Applied to stores in Europe, Japan and China	4000	18
CWF	(Cool White Fluorescent) American Standard	4150	18
F/A	"Sun-setting Light Yellow" incandescent light source (imitation of sunset)	2700	40
UV	Viewing under ultraviolet light to detect and evaluate optical brighteners or fluorescent pigments.	Wavelength: 365nm	20
U30	Warm White Fluorescent, American Standard	3000	18

2.3 Features

2.3.1 Taking the most advanced touch screen control technology.

2.3.2 To display the using times of each light source, single-use time and total time.

2.3.3 The cabinet has small energy consumption, high luminous efficiency

2.3.4 Light source with automatic switching, metamerism function

2.3.5 No need to warm up, not flashing, guarantees fast and reliable evaluation of color

2.3.6 Using the 32 bit micro controller

2.3.7 It is more convenient to replace the light source

3 Operation Introduction

3.1 Cabinet Installation

The cabinet includes five components as shown in Figure 3.1: a base plate, a back plate, two side plates, a upper cover

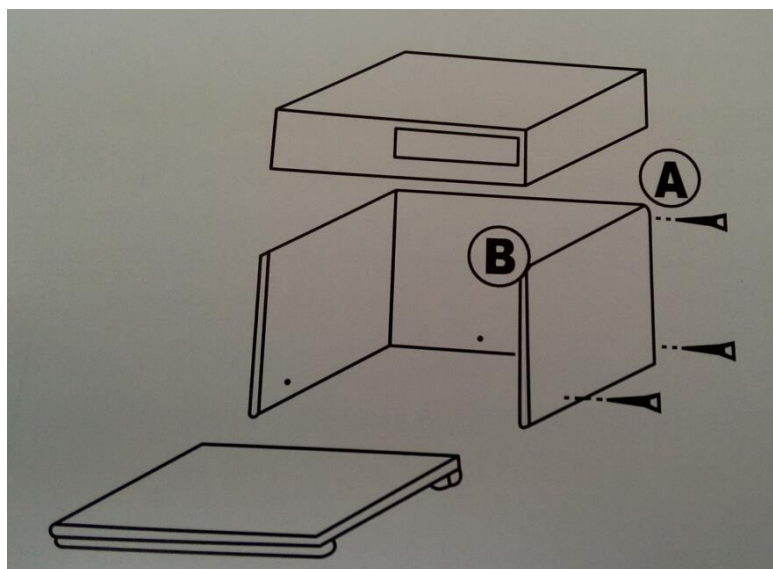

3.1

Installation method is as follows:

1. Fix the side plate with the pre-drilled holes on the back plate and the bottom plate with the screws attached, must ensure that the back plate in the rear edge of inner side plate, as shown in 3.2.
2. The wall panel can not be anti loaded, must ensure that the gray light absorbing surface towards the inside of the box body.
3. Place the upper cover with light source right above to the back plate and the side plate, the right positive with the slot, as shown in B with Figure 3.2 .

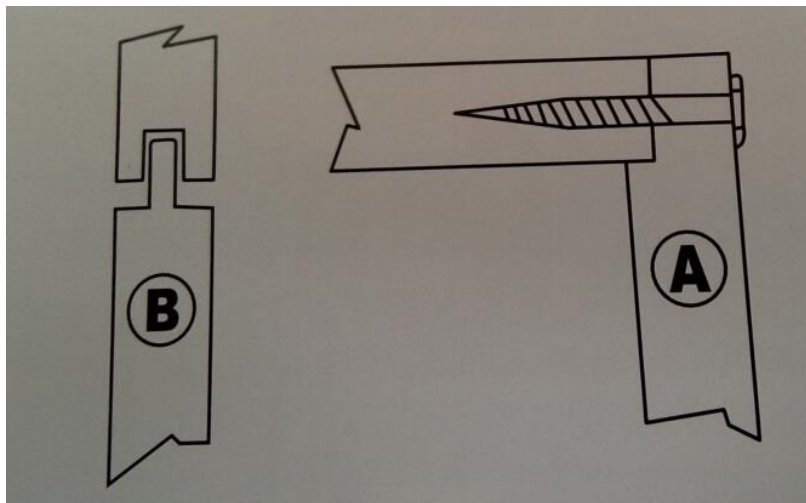

3.2

3.2 Construction

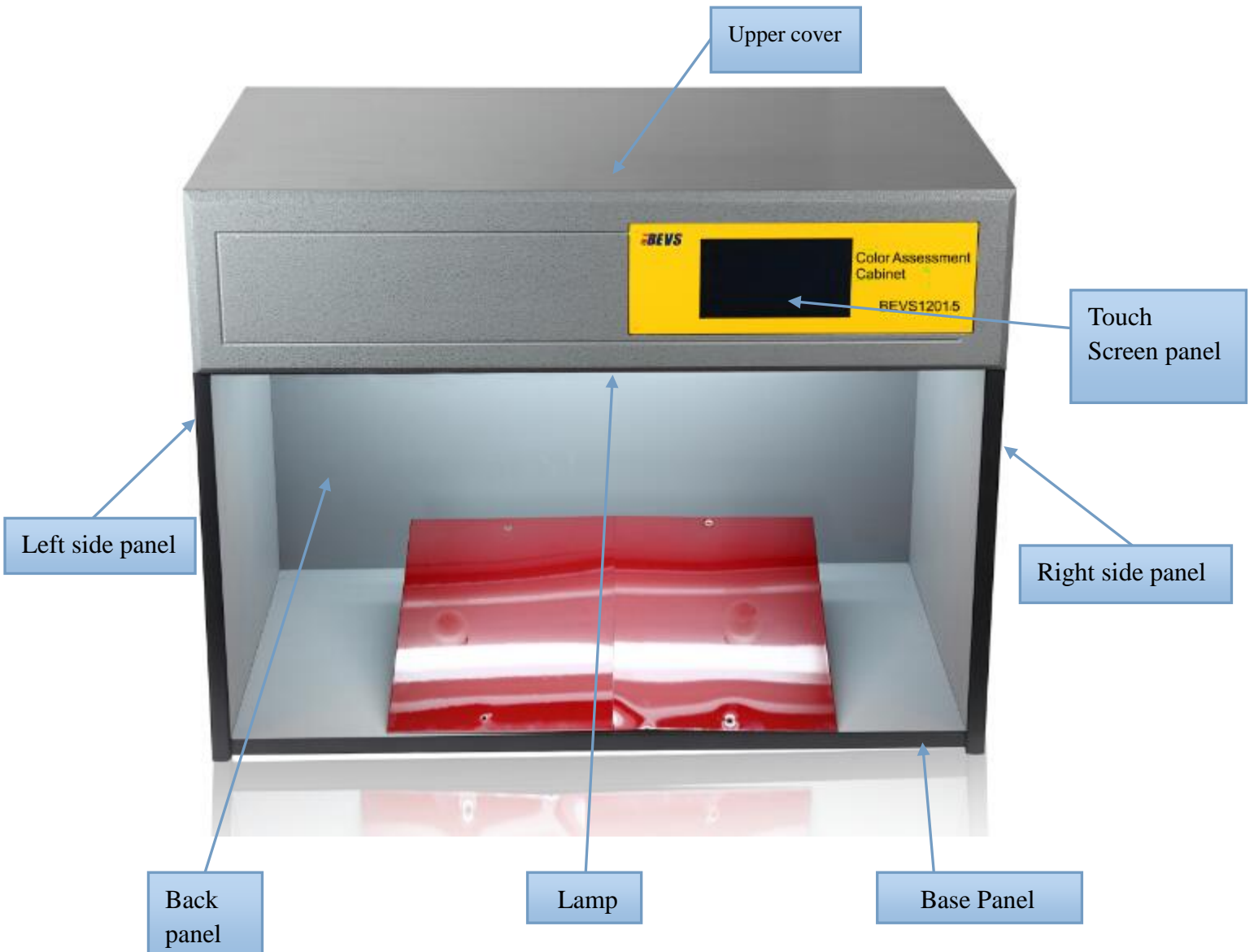

3.3 Operation Guideline

3.3.1 Connect the power (220V,50Hz)

3.3.2 Turn on the power switch, the switch is located on the back of the instrument

3.3.3 Enter the welcome screen and select the language

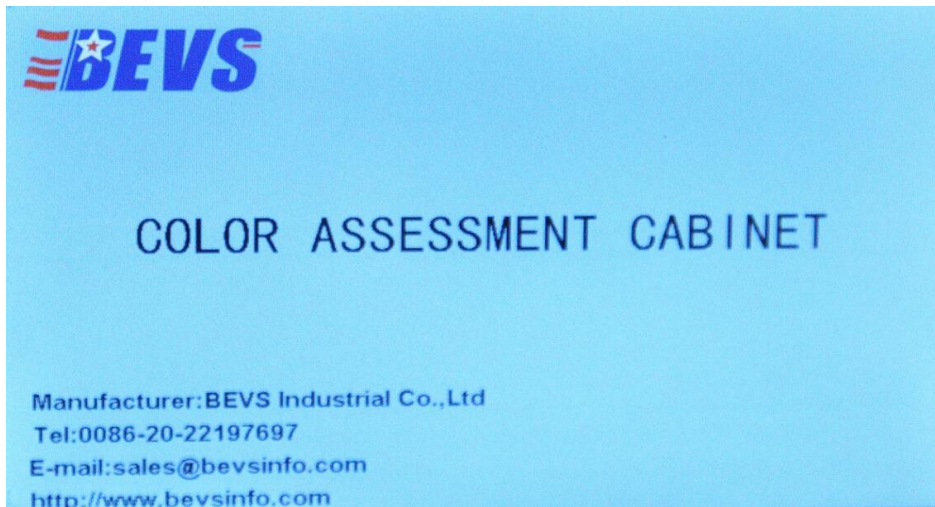

4.1

3.3.4 Place the product on the working platform, observe with light angle 90° ; 45° line of sight is better, shown in Figure 4.2.

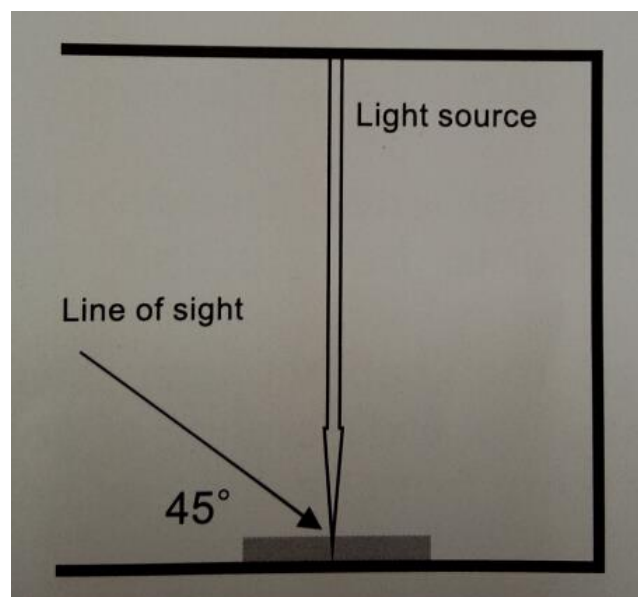

4.2

3.3.5 After checking all the test conditions are ripe, click on the corresponding source "ON" button to turn on the light began to observe the corresponding test in Figure 4.3

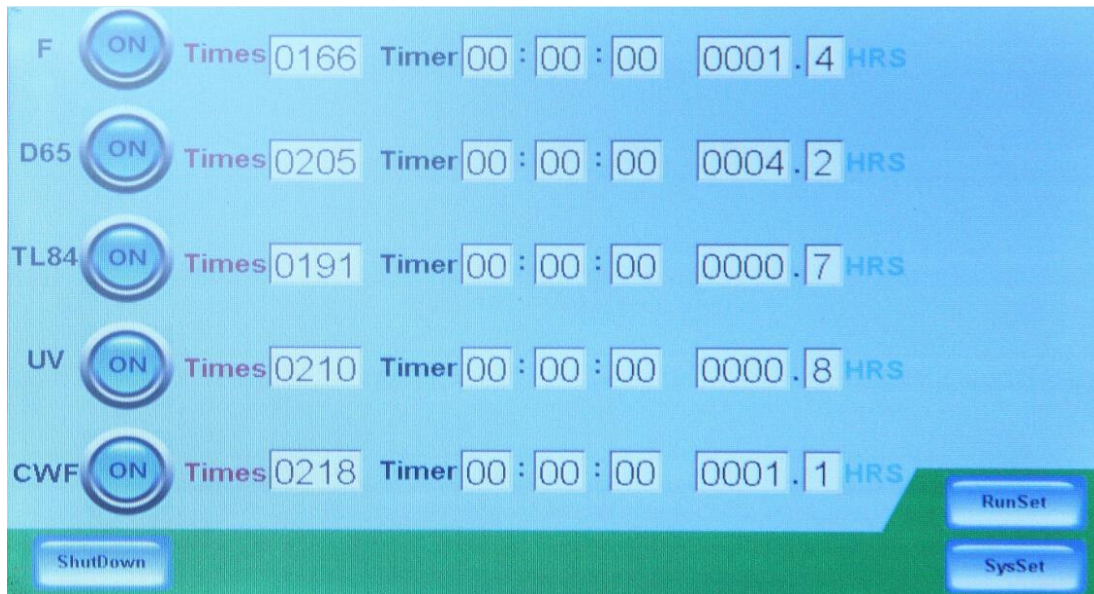

4.3

3.3.6 During the process, we can turn off the lamp to terminate the test by clicking the button "OFF".

3.3.7 When the observation process need to open multiple light sources to observe the test ,Run Setting” can be selected to run in the free mode, you can open multiple sources at the same time as shown in Figure 4.4.

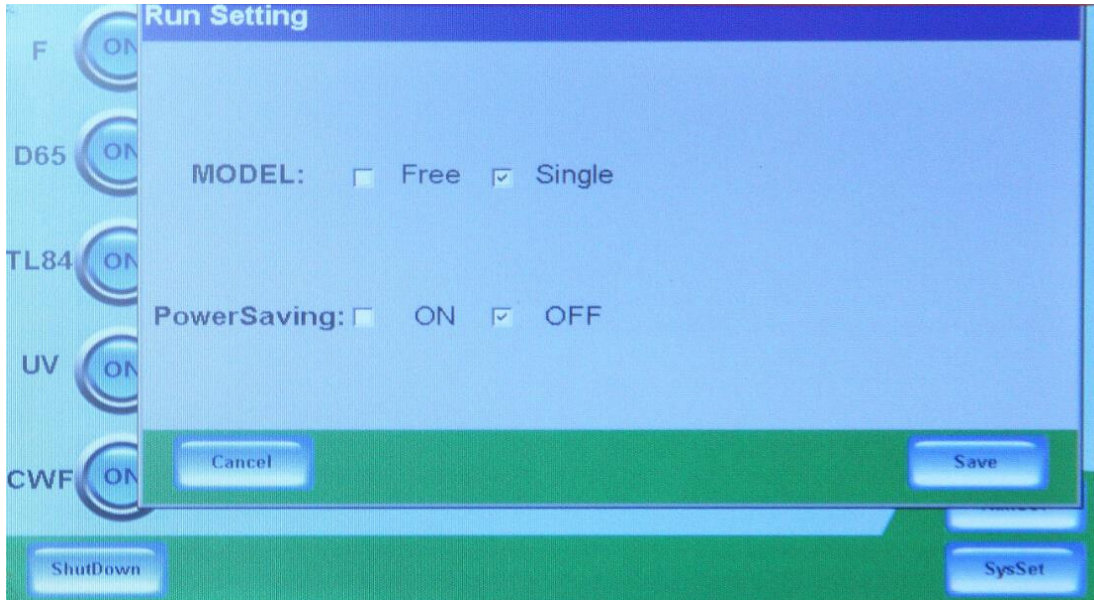

4.4

3.4 System Settings

3.4.1 Can replace the screen brightness

3.4.2 Open or close the buzz

3.4.3 Choose “ON” of Power Saving , if the user does not click on the screen for a long time ,the device will go into standby status ,and turn off the screen backlight.

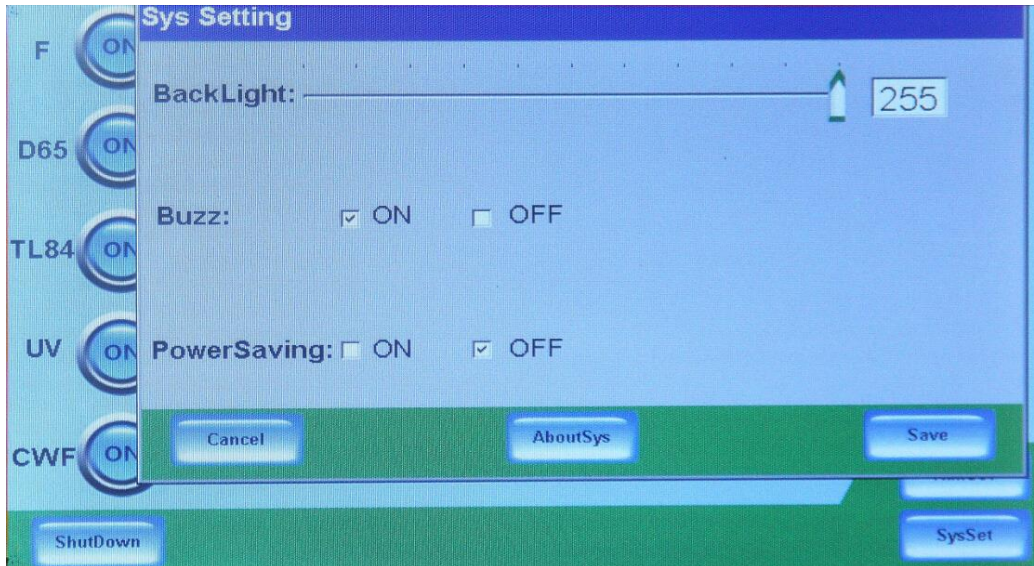

3.4.4 All settings must be saved before the effective, if not saved directly back to the previous menu, all settings are invalid.

4. Maintenance

4.1 Regular maintenance is necessary

4.2 Make sure that the instrument is being in off status and the power is being in outage status

4.4 Clean with the soft cloth, forbid to use the chemical reagent with corrosive

5. Attention

5.1 This equipment uses 220V / 2A design, non-professional and technical personnel disassembly is

prohibited.

5.2 To prevent systematic errors arising from the aging of the light source, the timer is better not more than 2000 hours.

5.3 Pay attention to the angle of observation, to maintain a 45 degree perspective is preferred.

5.4 Do not leave sundries in the cabinet, put only two items for colorimetric using, in order to avoid the impact of color effect.

5.5 Must adopt the standard lamp, consistent the light with customer requirements as much as possible.

6. Packing List

No.	Name	Item/Specification	Unit	Quantity
1	Host (a upper cover, a base plate, a back panel, two side panels)	BEVS1201/5 ,BEVS1201/6	set	1
2	Lamp	D65	pc	2
		TL84	pc	2
		CWF	pc	2
		F	pc	4
		UV	pc	1
		U30	pc	2
3	Power Line		pc	1
4	User Manual		pc	1
5	Certificate of conformity		pc	1
6	Screw		pc	9

7. Order Information of Accessories

BEVS 1201/5 D65 TL84 CWF F UV

BEVS 1201/6 D65 TL84 CWF F UV U30