

CR-6103

3 Tons Mid-Rise Scissor Lift

3吨超薄举升机

Feature:

- 1.Surface mounted 120mm to ground when installed.
- 2.All the pumps , seal kits of cylinder, ball valve import from italy.
- 3.All the hydraulic cylinder are import from TaiWan.
- 4.Inside of cylinder assy has the special treatment and make sure that is doesn' t leak oil.
- 5.24V control system and limited switch.
- 6.While switch is added, it is controlled long distantly.

特点:

- 1.地面式安装，最低高度120mm。
- 2.全套泵站，油缸密封件，球阀进口意大利。
- 3.液压油缸进口台湾。
- 4.油缸内壁镜面处理，确保油缸不漏油，保证两边同步性。
- 5.24V控制系统，24V限位开关装置。
- 6.外部配有拖线开关，可以远距离控制。

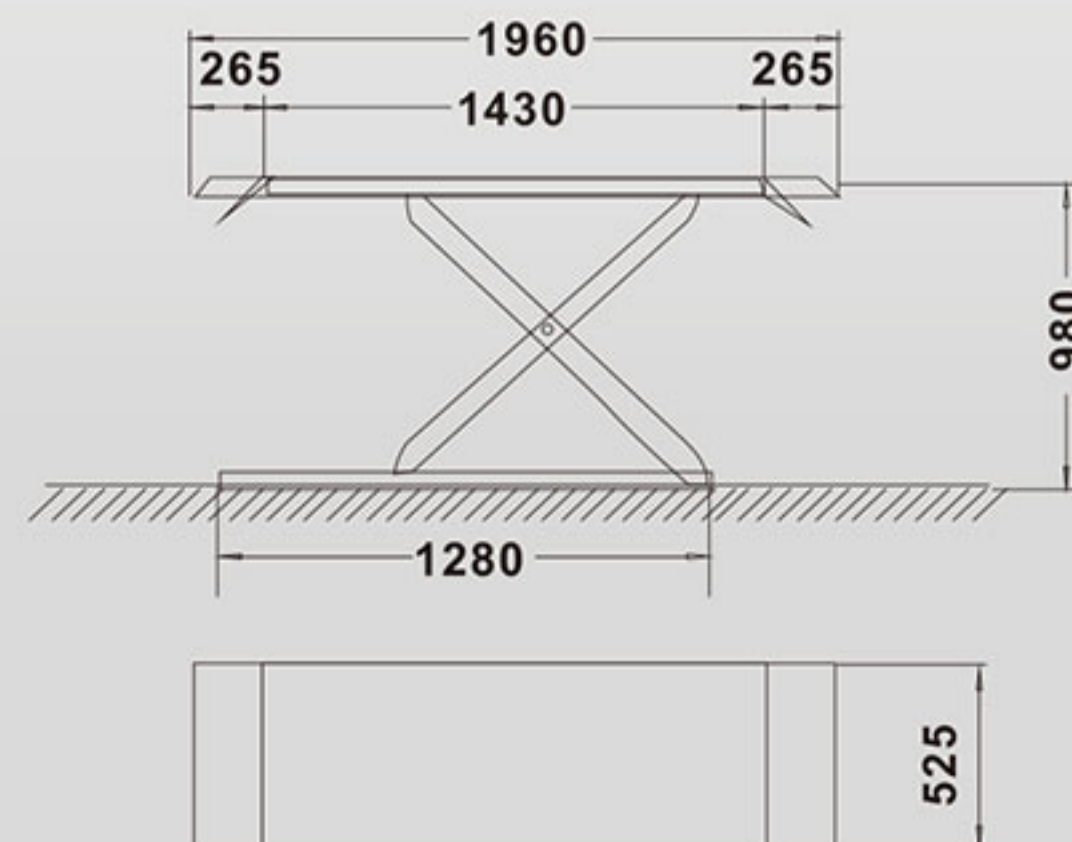

SPECIFICATIONS 技术参数

Load capacity 举升重量	3.0Ton	Power Supply 电压	3PH/380V or 1PH / 220V
Power 功率	1.5Kw	Lifting Height 举升高度	120-980mm